

**EPR**

ELECTRIC POWER  
RESEARCH INSTITUTE

## Superconducting DC Cables for High Power Transport over Long Distances

**Steven W. Eckroad**

Program Manager, Underground  
Transmission

**IASS Workshop – “Transporting Tens of  
GWatts of Green Power to the Market”**

12-13 May 2011

Potsdam, Germany

# Motivation: Moving Remote Power to the Marketplace

- Why cables?
  - Underground, out of sight
  - Smaller right-of-way
- Why DC?
  - AC cables limited to tens of miles
- Why superconducting DC?
  - Higher power and longer distance than copper
  - Lower losses
  - Use distribution voltage
  - Reduces transmission system's carbon footprint

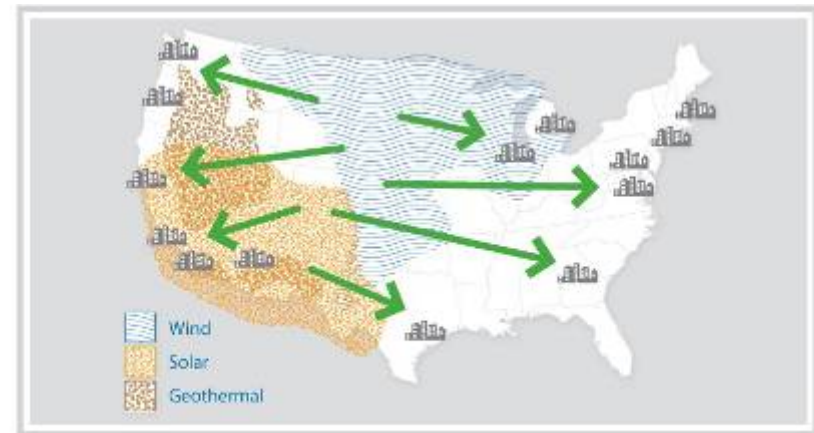

Source: AWEA and SEIA, "Green Power Superhighways" - February 2008



# Why Superconducting DC Cable?

To obtain, in a single technology, the:	EHV AC	HVDC	DC cable		HTS DC
Massive power transmission capability of EHV ac and HVDC				➔	
Cost advantages of HV dc over EHV ac				➔	
Multiple interconnection capability of ac				➔	
Unobtrusiveness & high reliability of underground dc cables				➔	
System control features of dc systems				➔	
Minimal right of way of underground cables				➔	

# Background For Workshop Attendees

- Superconducting DC cable system designed by the Electric Power Research Institute:
  - 1000-mile, 10 GW+ system
  - Uses today's technology
  - Cost competitive at achievable component prices
- Conceptual design – optimization and detailed engineering needed
  - Cable design and fabrication
  - Cryogenics and vacuum
  - Insulation and dielectrics
  - Converters and controls
  - Grid interface
  - Superconductors
- EPRI reports document results (free)





# Cable Manufacture with Conventional Factory Equipment and Processes

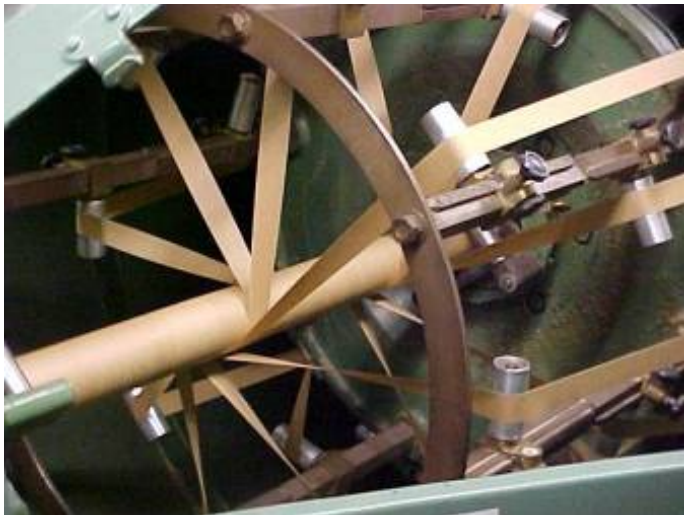

# Cable Topologies – Adapt Conventional Submarine Cable Technology

## Monopoles

a. Integrated LV Return

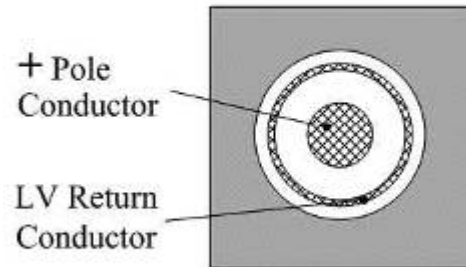

b. Separate LV Return

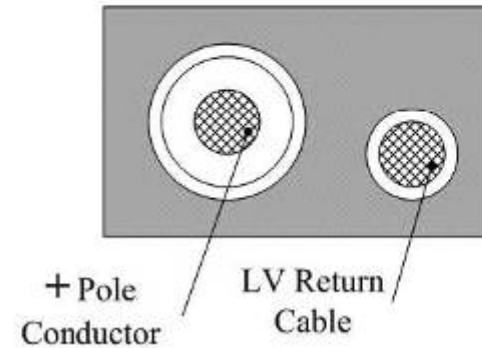

**EPRI Cable a Hybrid: Monopole with Integrated Bipole Insulation**

## Bipoles

c. Integrated Poles

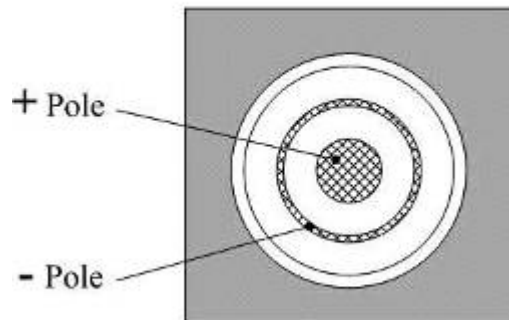

d. Separate Poles

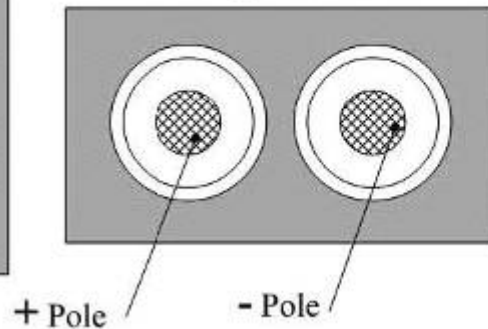

e. Separate Poles with LV Return

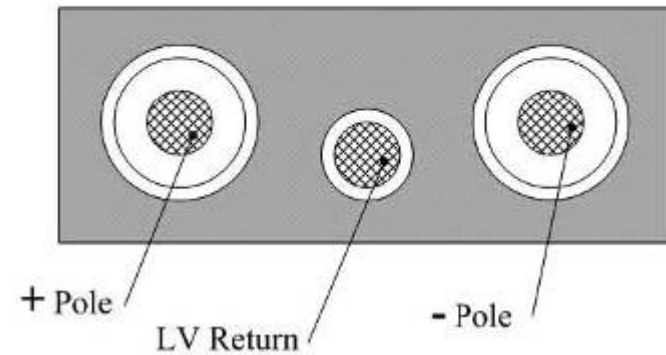

# Cable Core Installed Within Vacuum Cryostat

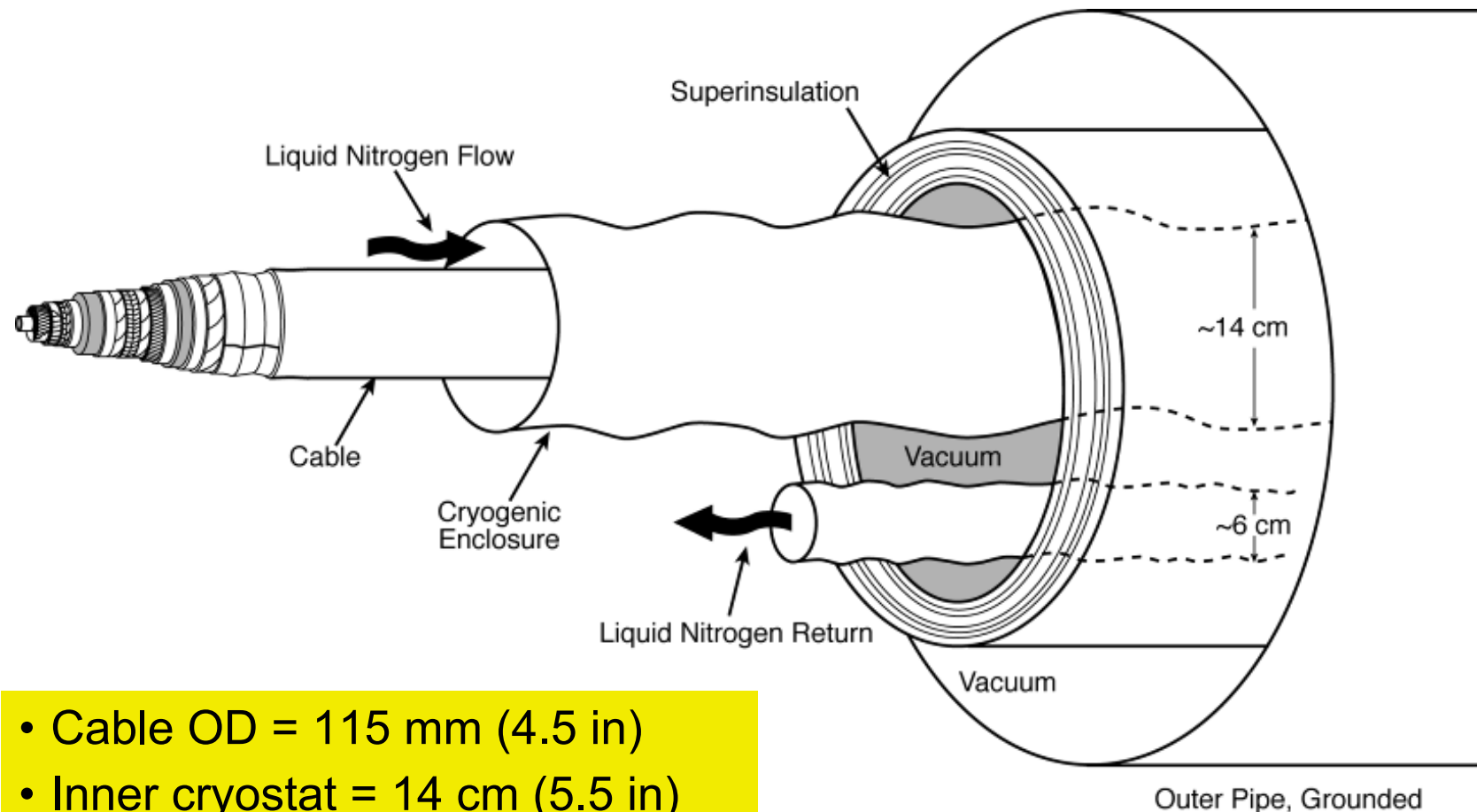

- Cable OD = 115 mm (4.5 in)
- Inner cryostat = 14 cm (5.5 in)
- Outer cryostat ~ 70 cm (~30 in)

# Factory Fabrication and Shipping

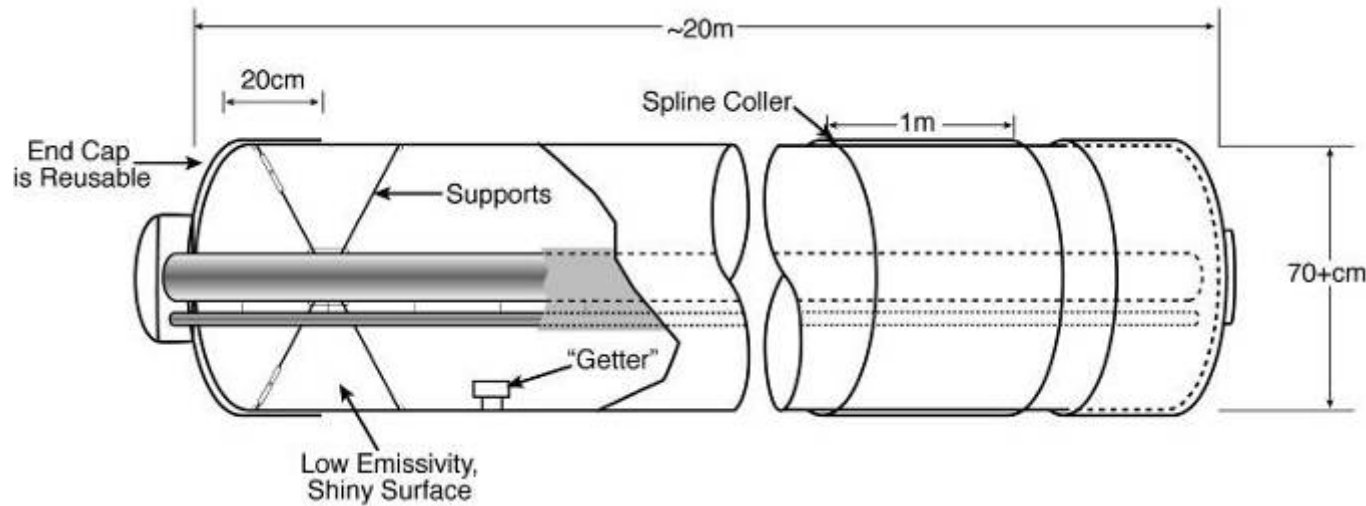

Critical cryogenic enclosure, supports and insulation fabricated in factory

Completed cryostat sections with protective end caps shipped to field on standard transports

Pipe Transport

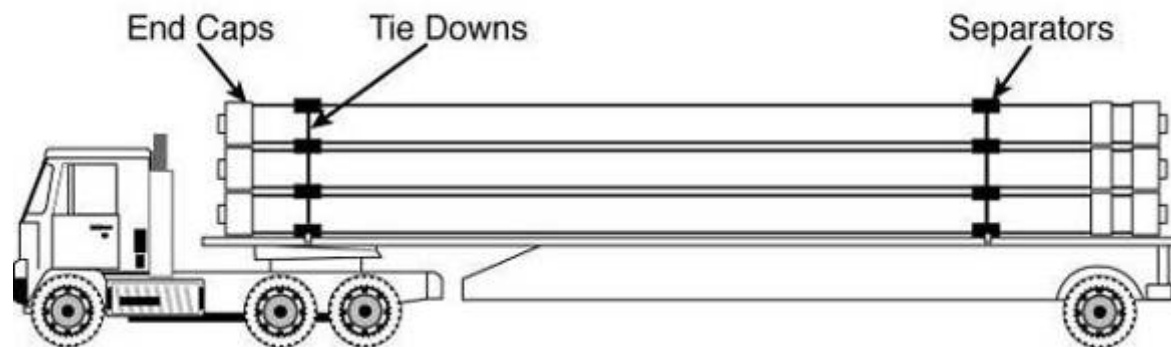



# Installation Essentially Same as Gas Pipelines and Conventional UG Cable



**Natural Gas Transmission Pipeline and Pumping Station**

*Source: Duke Energy Gas Transmission Canada*

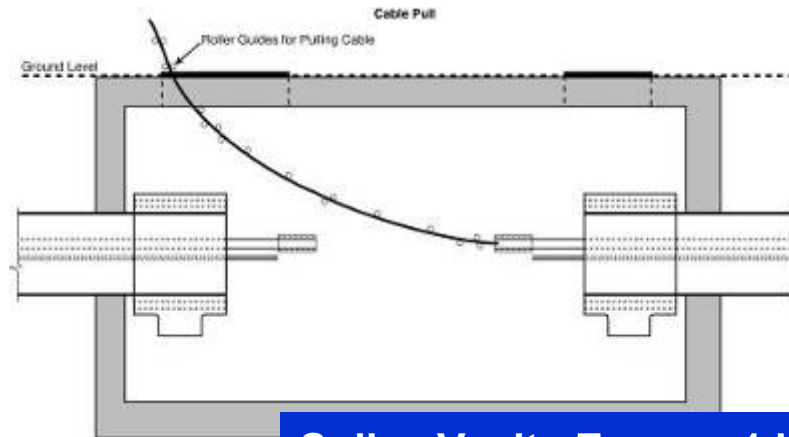

**Splice Vaults Every ~ 1 km (0.6 mi.)**



**Vault design, installation, and cable pulling follow conventional underground transmission cable practice**

# Refrigeration Stations

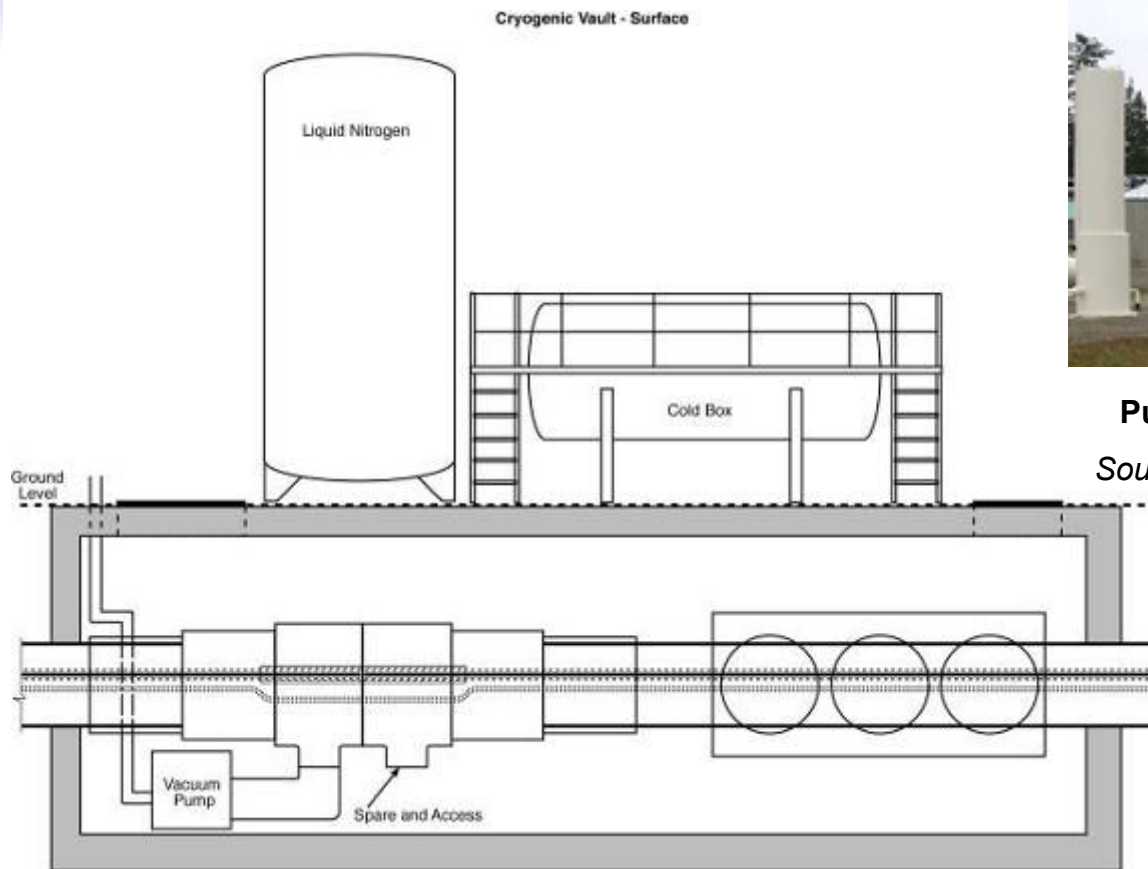

**Pumping station for a natural gas pipeline**  
*Source: Duke Energy Gas Transmission Canada*

**Refrigeration  
Stations Every  
~ 20 km (12 mi.)**

Conceptual designs developed for pipe connections, cable splices, vacuum and refrigerator placements, etc.

# Functional Criteria Determined for Thermal Insulation Design

- Method of maintaining vacuum is key decision point
- A very long transmission cable demands reassessment of conventional HTS cable design practice
  - Long-term reliability is critical
  - Factory sealed cryostats have unacceptable leak rates
- Vacuum has lowest heat flow
  - Vacuum quality determines heat influx and hence refrigeration requirements
  - Both out gassing and potential leaks must be addressed
- Non-vacuum insulation needs to be evaluated
  - Simpler, but higher refrigeration loads expected

# Heat Loads Calculated

- Heat sources
  - Conduction
  - Convection
  - Radiation
  - AC losses = hysteresis from current changes and ripple
  - Cable ends / joints
  - Cryogen flow losses
- Used nominal heat load of 1 W/m for initial calculations

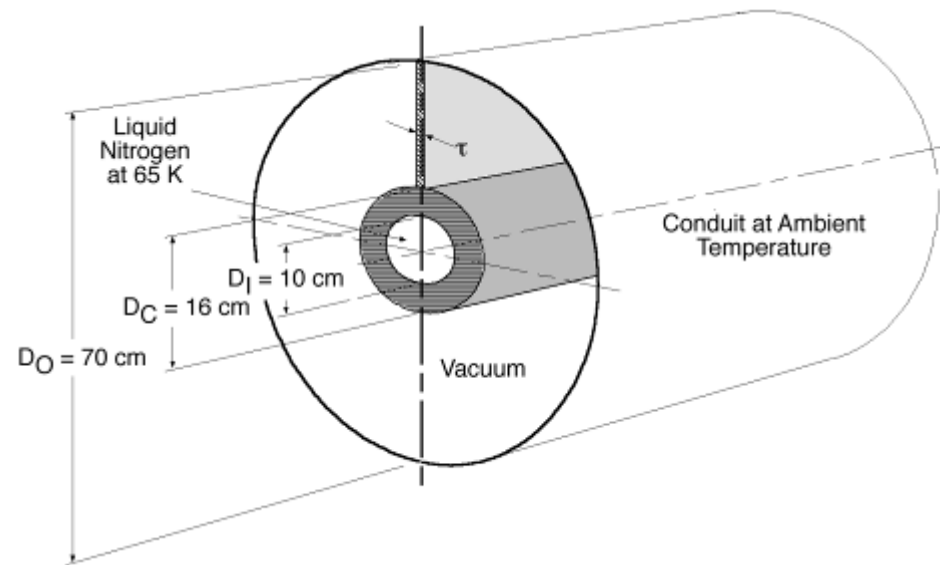

Simplified design for cryogenic and vacuum calculations



# Computer Aided Calculations For Cryogenic Cooling System Design

- Four design parameters required somewhat arbitrary choices, having cost and reliability impacts
  - Refrigerator station separation
  - Initial temperature of cryogen
  - Temperature rise allowed between refrigerator stations
  - Maximum pressure drop between refrigerator stations
- Cable traversal of diverse environments requires variation of these over entire route length

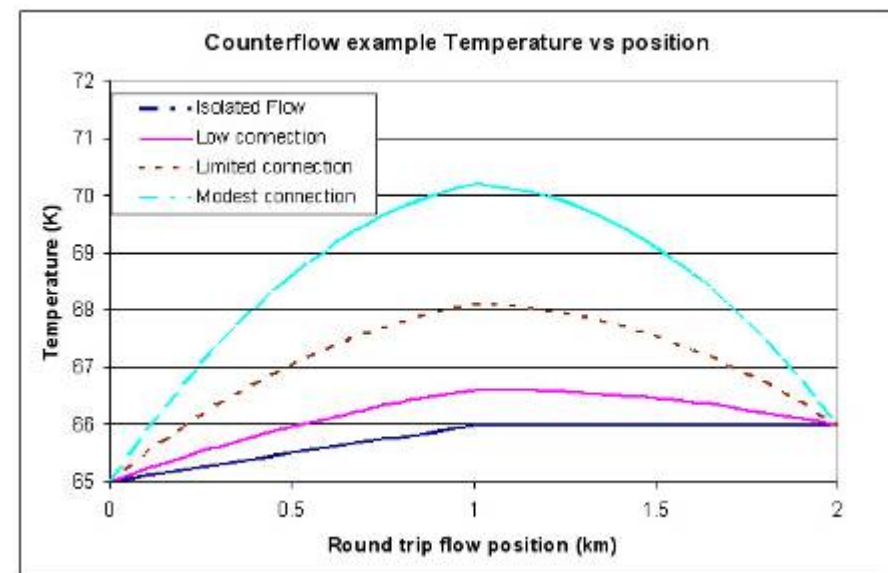

# Interface to AC Grid Achieved With Commercial DC-AC Technology

- Converter topologies evaluated
  - Voltage source (VSC) and current source (CSC)
  - Each has strengths & weaknesses
  - Multi-terminal design requires VSC
- Electrical ground design
  - Superconducting cable must be isolated from ground
  - AC resistance is not zero so transients can introduce voltages and circulating currents
  - Cable neutral grounded at single point (per NESC)

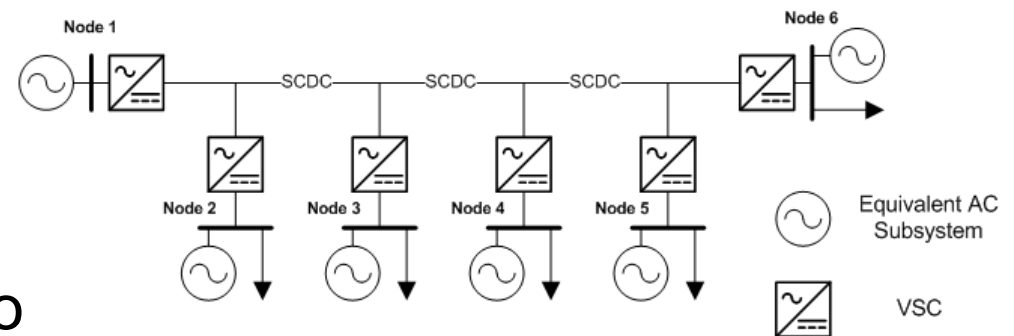
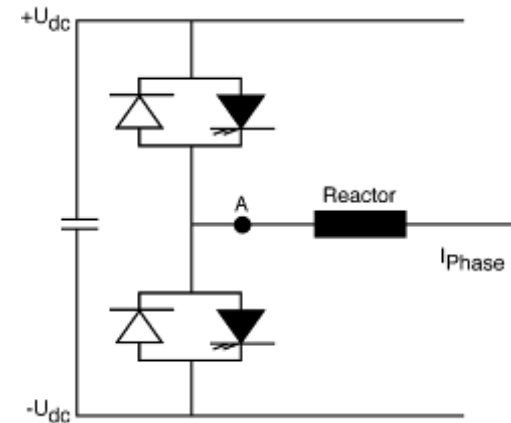

# Study of Transients and Harmonics on DC Cable

- Simulation comprised two VSCs with basic controls configured as a two-terminal system
- Results and analysis show feasibility of multi-terminal systems based on VSC converters, but issues remain:
  - Steady state harmonic injection into the cables can be managed to an arbitrary level using harmonic filters
  - AC system voltage sags and short circuits will affect the availability of a multi-terminal dc system
  - Fast acting, semiconductor-based DC circuit breakers may be needed to disconnect converters from the dc circuit in case of cable-side short circuits

# AC System Integration Studies

- EPRI study showed loss of multi-GW line would not cause cascading failures in Eastern and Western grids
  - Grids can accommodate loss of 8 to 10 GW
  - Dual redundant cable design provides extra measure of reliability

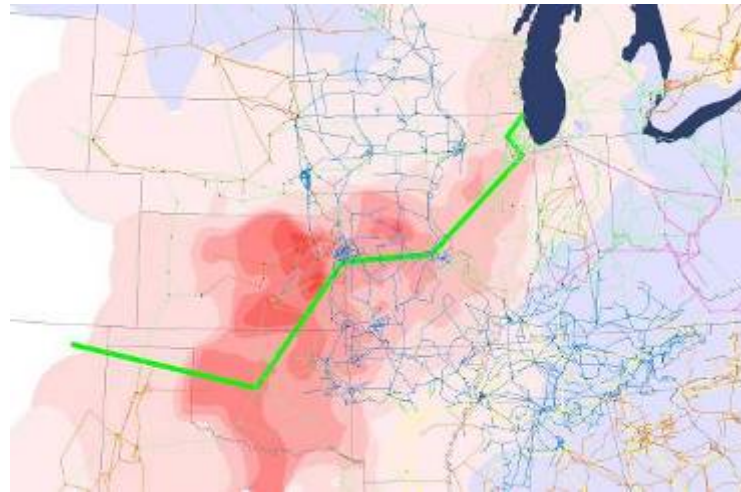

- Advantage of multiple, small converters is location near load centers
- But, control systems for multi-terminal VSC-based cable must be fully assessed for all possible system events



# Cost & Loss Comparison: 5 GW, 1500 Mile Transmission Line

	AC 765 kV	HVDC +/- 800 kV	HTS DC @ \$50/kA-m wire cost (\$20/kA-m would halve costs):		
			100 kV dc	200 kV dc	400 kV dc
Station cost, \$M (incl. compensa.)	2300	940	750	750	750
Line cost, \$M/mi (wire only)	5.2	3.6	14.5 (9.6)	9.8 (4.8)	7.4 (2.4)
Line cost, \$M (\$/kW-km)	7,800 (\$0.62)	5,400 (\$0.43)	22,000 (\$1.70/kW-km)	15,000 (\$1.20/kW-km)	11,000 (\$0.90/kW-km)
<b>TOTAL</b>	<b>10,000</b>	<b>6,300</b>	<b>23,000</b>	<b>15,000</b>	<b>12,000</b>
Losses at full load	13.3% (665MW)	12.7% (635MW)	5.0% (250MW)	5.0% (250MW)	5.0% (250MW)
Capitalized cost of losses, \$M	1000	950	380	380	380

765 line: 2 single ckt, 6 bundle Drake; substation losses @ 1.7%. 800 kV Bipolar line: 6 bundle Drake; converter losses @1.5%. HTS DC line: losses assume 1 cold W per meter with 12 W per W refrigeration & 3% for VS converters.

AC and HVDC costs based on ABB costs (IEEE PSCE 2006) for 3000 MW, 750-mile line, escalated @ 2.5% per year. HTS DC line costs per EPRI 1020458, Appendix C. Cost of losses capitalized @\$1500/kW using 10% interest rate [ABB].

# Projected YBCO Conductor Costs

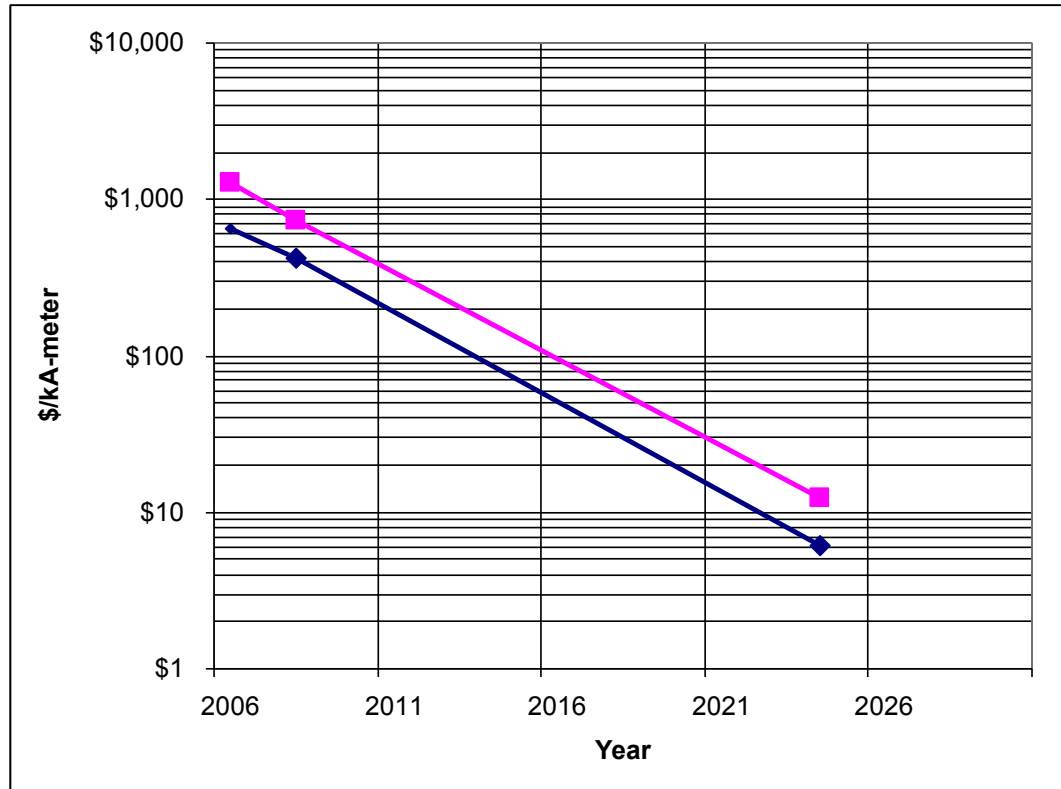

Based on TR-110719, p 4-8: Cost (w/o profit) in \$/m=1.12 1999\$ (~1.55 \$/m in 2010\$)

Assume \$/m costs reach maturity 25 years from estimate in report

For "High" end cost of mature tapes assume tapes are 125A (derated) -->  $8 \times \$1.55/\text{m} = \$12.4/\text{kA-m}$

For "Low" end cost of mature tapes assume tapes are 250A (derated) -->  $4 \times \$1.55/\text{m} = \$6.20/\text{kA-m}$

# Application for DC Superconducting Cable: DC Macro-Grid™ For Transmission Flow Control

- Multi-terminal dc transmission ring
  - Feeds all local or regional loads
  - Wheels distant power around (not through) area
  - Voltage source converters (VSCs) act as local generation
  - Full control over all power flows
- Isolates local or large-scale geographical area
  - AC-DC-AC power grid interface
  - DC “extended bus” handles all ac power transactions
  - Local area becomes asynchronous AC

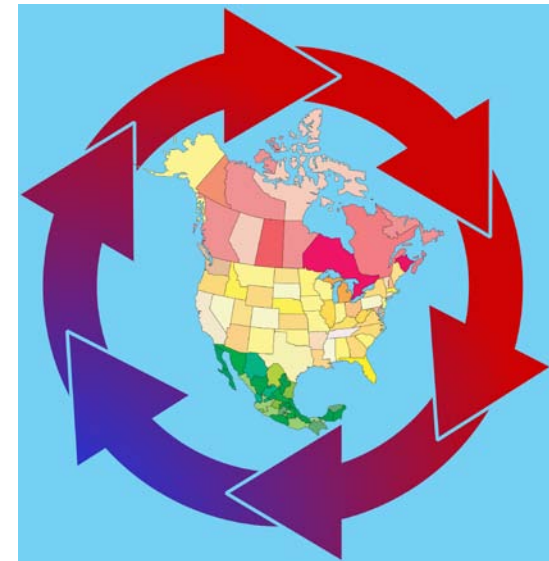

# EPRI DC Macro-Grid™

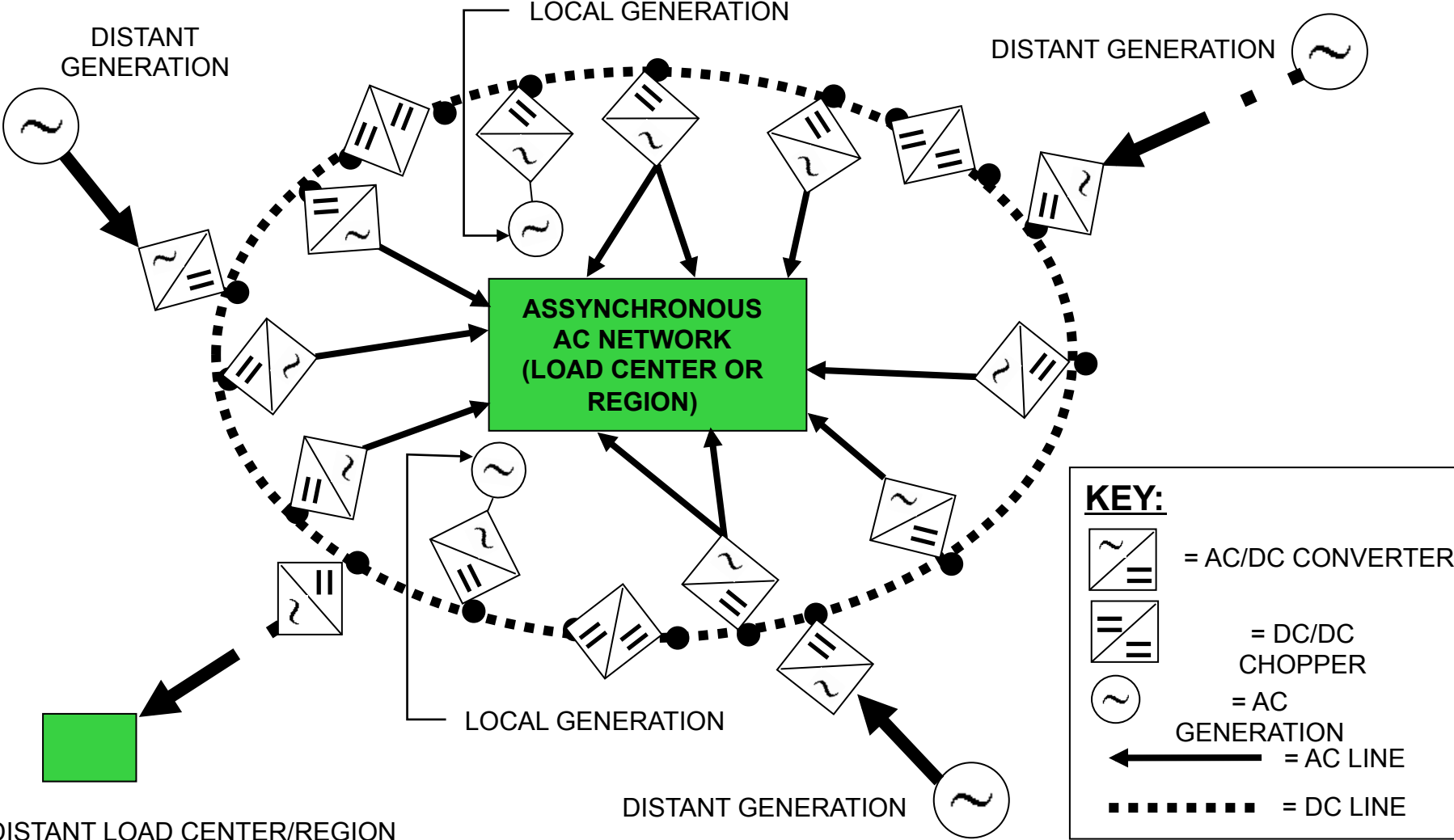



# Remote Green Power to Urban Asynchronous Networks Via Multiple DC Macro-Grids™

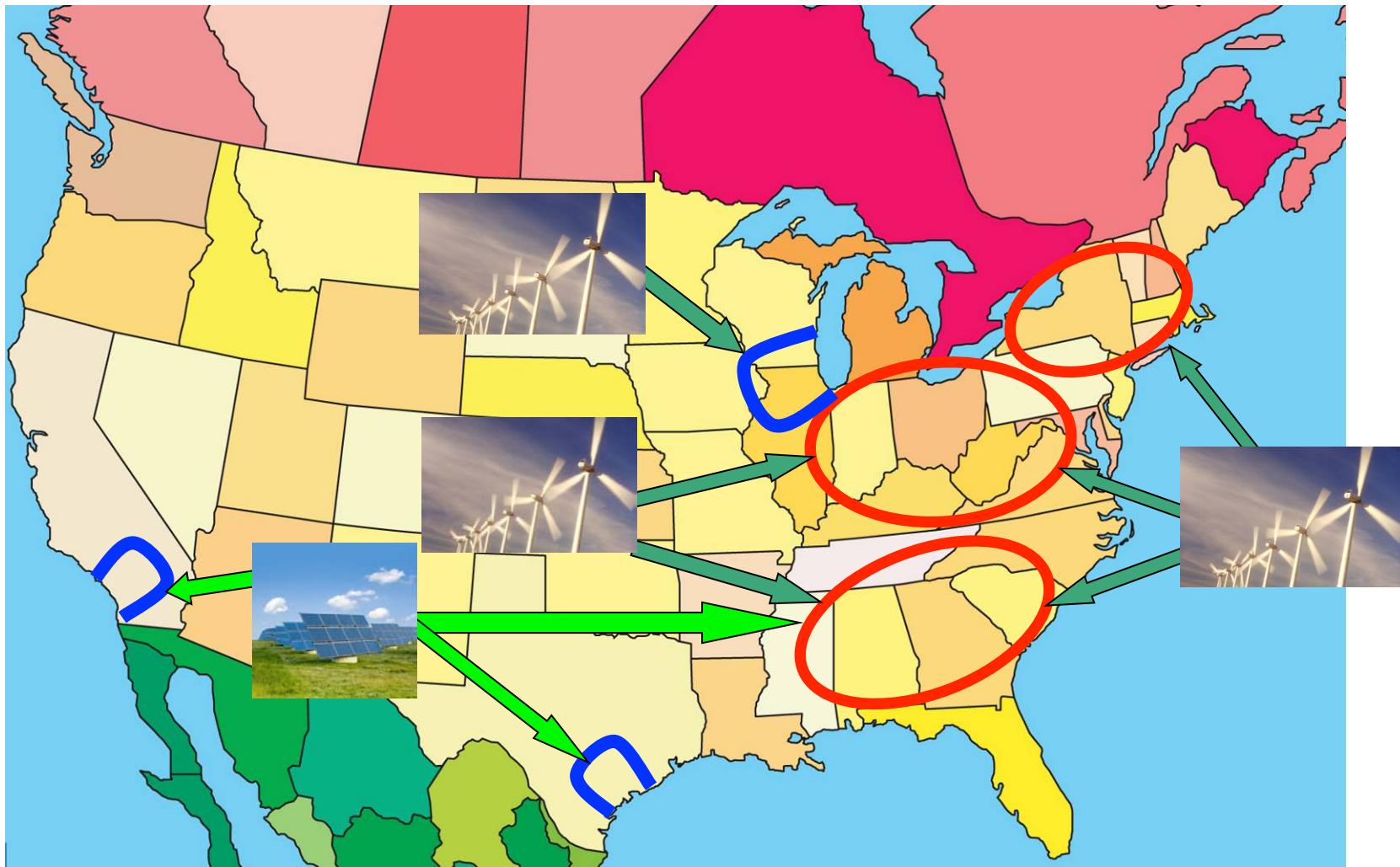

# Remote Green Power to Urban Asynchronous Networks Via Multiple DC Macro-Grids™

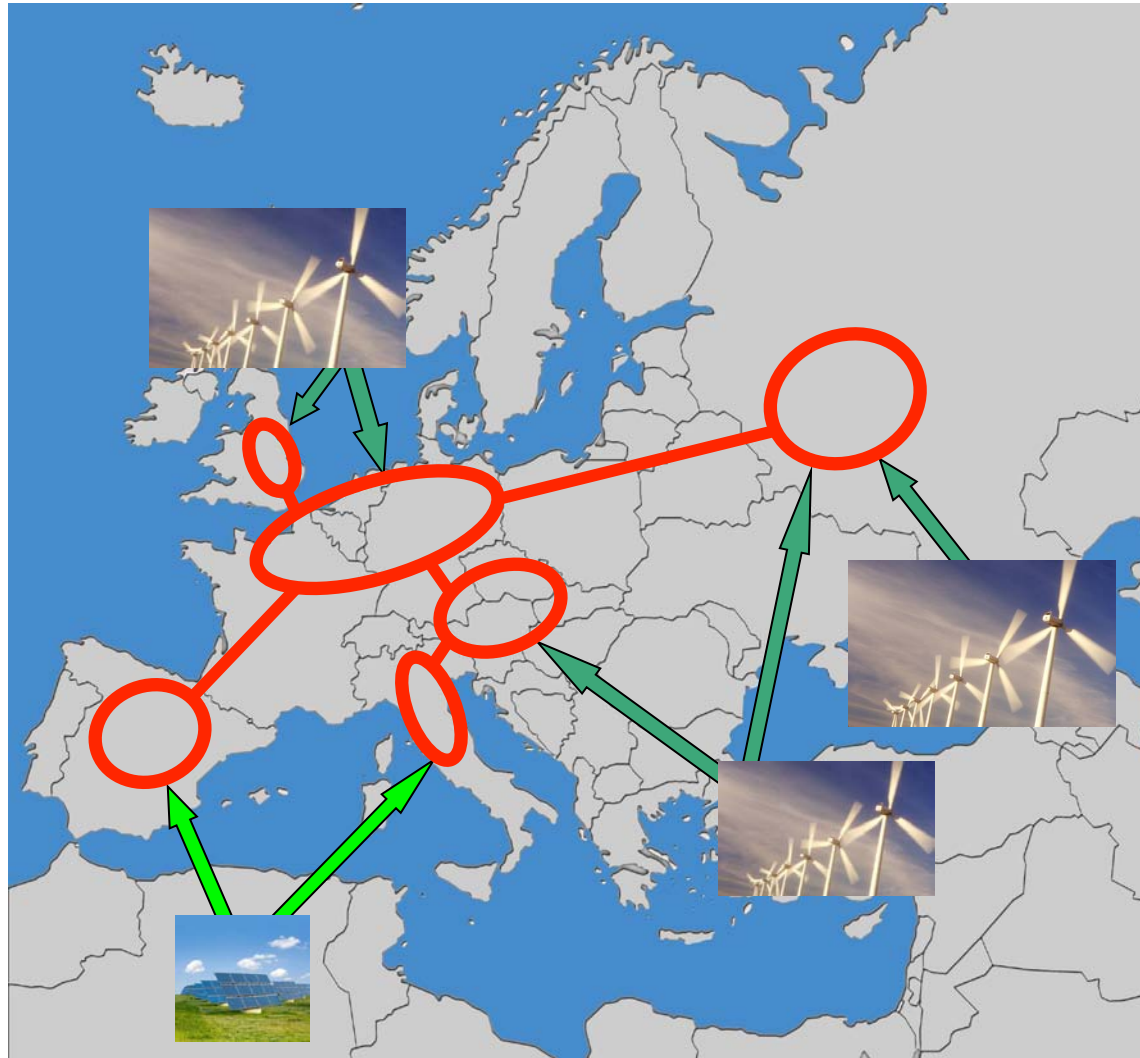

# Recommended RD&D Program for High Power Superconducting DC Cables

- A phased research program should be adopted to systematically arrive at a commercial prototype
  - See EPRI reports for detailed tasks
- First goal is to test the overall design concept
  - Model system would provide critical, early evaluation of an integrated system
  - Model system should include all mechanical and electrical components
  - Full power not needed but independent current and voltage tests should be made
  - System of 60 to 120 meters could be built
- Model system test results will indicate next steps in design

# Summary

- A long distance high power superconducting dc cable has been taken to a level of engineering design that shows it to be:
  - Practical and ready for commercial development
  - Capable of being built using today's technology
- Should large (5-10 GW) remote generation become the norm in the next few decades
  - Methods of transmitting this level of power over long distances will be needed
  - The superconducting dc cable is a promising, if not the ideal, means to that end
  - Novel “ring” structures could enhance power flows
- The next step is to build a model cable system



# Together...Shaping the Future of Electricity



# Appendix

---

# Cryogenics

- Superconductivity requires a low temperature
  - 65 to 70 K for liquid nitrogen
  - Over distances of a 1000 km
  - Small temperature variations
    - Normal operation  $\pm \sim 1$  K
    - Upset/fault conditions  $> +5$  K
- Requires pressurized flow of liquid nitrogen
  - Pressure of several atm required to limit bubble formation and to maintain consistent dielectric strength
  - This “low” pressure allows the use of thin walled pipes
  - Which, in turn, limits the allowable pressure rise caused by flow resistance

# Interface to AC Grid Achieved With Commercial DC-AC Technology

- DC power transmission technology successfully integrated into transmission grids for 50+ years
- Newer voltage source converters (VSC) offer significant advantages for superconducting dc cable
  - Flexibility of control
  - Multiple terminals
  - Reactive support to the ac system

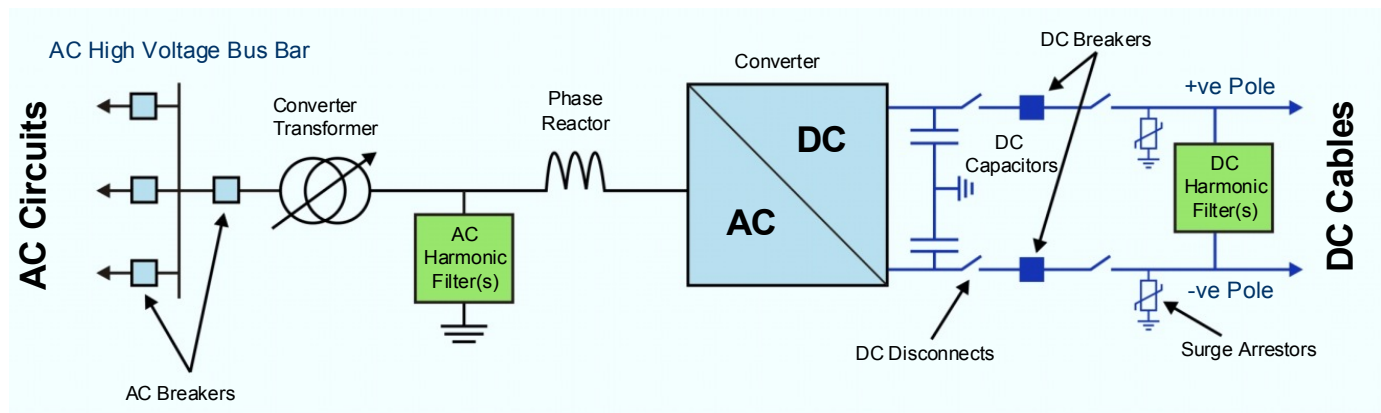

# Next Steps – 1

- DC cables with high currents and/or high voltages ( $> 20$  kA,  $>100$  kV) present challenges
  - Current distribution among HTS wire layers
  - Cable splices and terminations
- HTS and cryogenic dielectric material cost and performance strongly impact commercial viability
  - Critical current
  - Annual production volume and piece length
  - Price, Etc.
- Optimization required for converter/cable topologies
  - Ensure optimal system characteristics
  - Minimize cable manufacturing complexity, new related product development, and installation costs

## Next Steps – 2

- Cryostat costs must be reduced while ensuring reliability
  - Cost: Choice of materials and manufacturing processes
  - Reliability: Maintaining consistent thermal performance, containment of heat transfer fluid, and mechanical protection of the HTS dc cable
- Cryogenic, vacuum, and refrigeration systems capable of meeting the capacity requirements of long dc cables are available today
  - However, redundant components required for reliability
  - Trade study of various thermal insulation and cryogenic systems needed to determine future development
- Reliability must be addressed for all system components as design evolves
  - Failure modes and effects analysis are required
  - Mitigation by design, redundancy, or operational constraints



## Next Steps – 3

- A series of prototype cable systems of various lengths (10s, 100s, and 1000s meters) and of increasing levels of dc current and dc voltage need to be built and tested on an aggressive schedule
  - Testing and evaluation of cryogenic cooling, pumping, and thermal insulation schemes
  - Require development of dedicated test facilities with suitable voltage and current ratings, and refrigeration equipment
- Several trade studies critical to selection of cable design parameters
  - Comparing life-cycle cost and overall performance for different combinations of current and voltage
  - Comparing long term performance and costs of various thermal insulations schemes
  - Comparing various forms of electrical insulation
  - Exploring cost and performance of operating temperature and the use of different coolants